

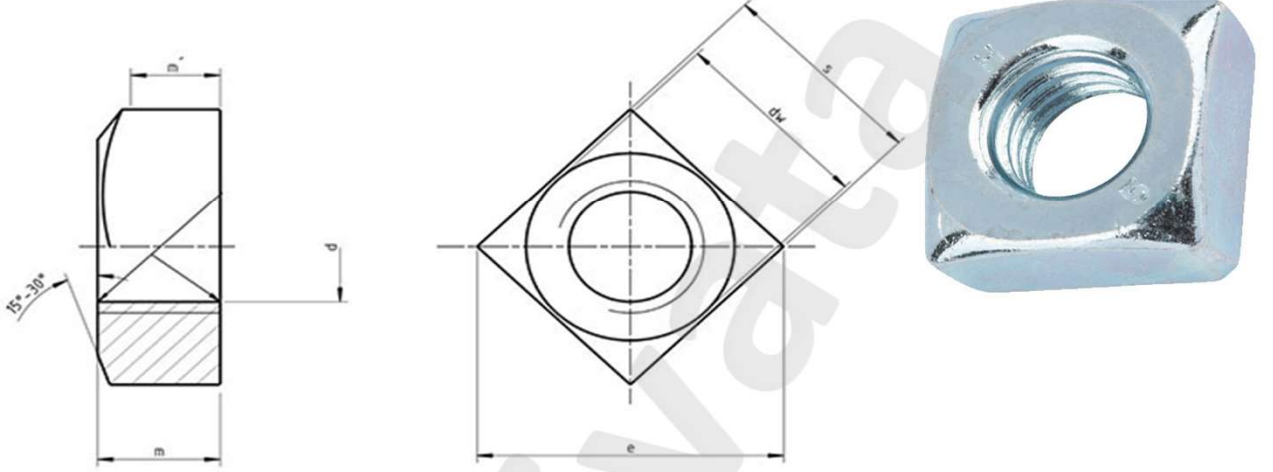

DIN 557 KONTRA KARE SOMUN
Square Nuts

DIN 557;
CSN 21624;
PN 82151;
UNI 5597;

* 6K
* A2 304
* A4 316



Thread	Ölçü d	M5	M6	M8	M10	M12	M16
P	Diş Adımı	0,80	1,00	1,25	1,50	1,75	2,00
dw	dw min.	6,70	8,70	11,50	14,50	16,50	22,00
e	e max.	11,30	14,10	18,40	22,60	25,40	33,90
	e min.	9,93	12,53	16,34	20,24	22,84	30,11
m	m max.	4,00	5,00	6,50	8,00	10,00	13,00
	m min.	3,52	4,52	5,92	7,42	9,42	12,30
mw	mw min.	2,50	3,20	4,10	5,20	6,60	8,60
s	s max.	8,00	10,00	13,00	16,00	18,00	24,00
	s min.	7,64	9,64	12,57	15,57	17,57	23,16