

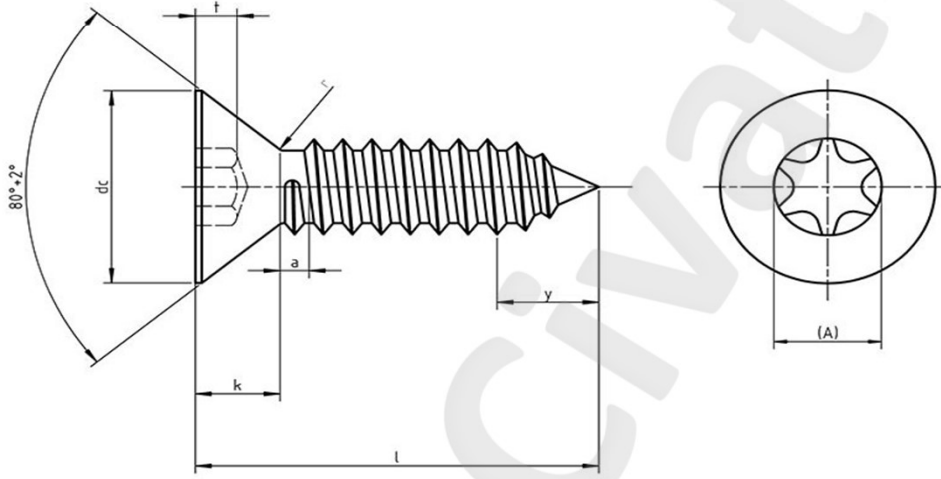

ISO 14586 TORXS HAVŞA BAŞLI SAC VİDASI



Ölçü d1	Ø 2,2	ST2,9	ST3,5	Ø 3,9	ST4,2	ST4,8	ST5,5	ST6,3
d2 max.	4,30	6,30	8,20	7,50	9,40	10,40	11,50	12,60
k max.	0,30	1,70	2,35	2,55	2,60	2,80	3,00	3,15
TORX	6	10	15	15	20	25	25	30
t max.	0,80	0,91	1,30	1,45	1,58	1,78	2,03	2,42