

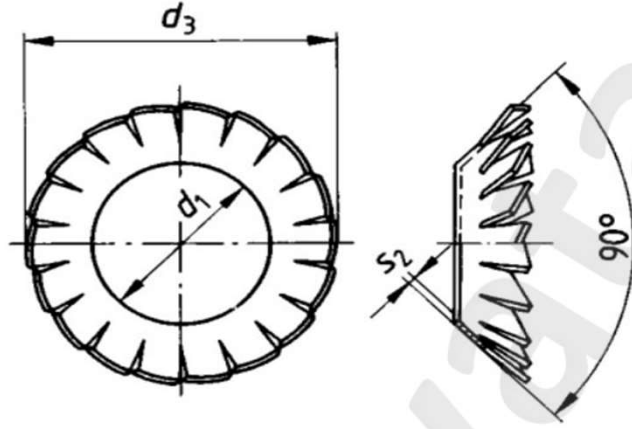

DIN 6798 V HAVŞA TIRTILLI PUL

DIN 6798 V;  
CSN 21745;  
UNI 8841;

\* ST Çelik,  
\* A2 304  
\* A4 316



Anma Ölçüsü	d1	d1 Min.	d1 Max.	d3	s2
M2	2,20	2,20	2,34	4,20	0,20
M2,5	2,70	2,70	2,84	5,10	0,20
M3	3,20	3,20	3,38	6,00	0,20
M3,5	3,70	3,70	3,88	7,00	0,25
M4	4,30	4,30	4,45	8,00	0,25
M5	5,30	5,30	5,48	9,80	0,30
M6	6,40	6,40	6,62	11,80	0,40
M8	8,40	8,40	8,62	15,30	0,40
M10	10,50	10,50	10,77	19,00	0,50
M12	13,00	13,00	13,27	23,00	0,50
M14	15,00	15,00	15,27	26,20	0,60
M16	17,00	17,00	17,27	30,20	0,60