

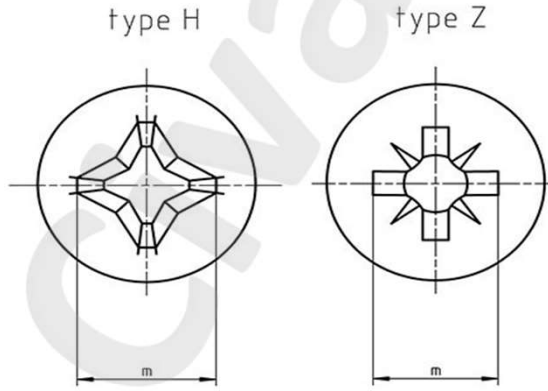

## DIN 7981 F ISO 7049 YILDIZ SİLİNDİR BAŞLI KÜT UÇLU SAC VİDASI

DIN 7981 F;  
ISO 7049;  
CSN 21235;  
UNI 6954;

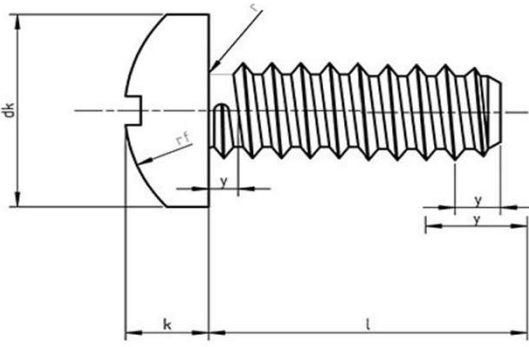
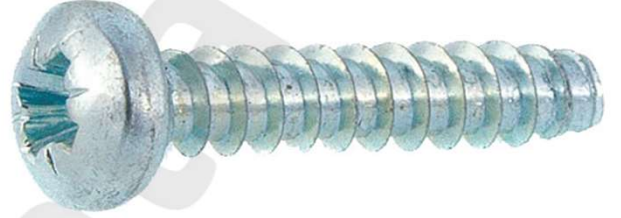

Ölçü d	2,2	2,9	3,5	3,9	4,2	4,8	5,5	6,3
Diş Adımı	0,80	1,10	1,30	1,30	1,40	1,60	1,80	1,80
amax.	0,80	1,10	1,30	1,30	1,40	1,60	1,80	1,80
dk max.	4,20	5,60	6,90	7,50	8,20	9,50	10,80	12,50
dk min.	3,90	5,30	6,54	7,14	7,84	9,14	10,37	12,07
k max.	1,80	2,20	2,60	2,80	3,05	3,55	3,95	4,55
k min.	1,55	1,95	2,35	2,55	2,75	3,25	3,65	4,25
r max.	0,30	0,40	0,50	0,50	0,60	0,70	0,80	0,90
rf	3,40	4,40	5,40	5,80	6,20	7,20	8,20	9,50
PH	1,00	1,00	2,00	2,00	2,00	2,00	3,00	3,00
Type H m	2,60	3,00	4,20	4,40	4,60	5,00	6,50	7,10
Type Z m	2,40	2,90	3,90	4,10	4,30	4,70	6,20	6,70
type y max	2,00	2,60	3,20	3,50	3,70	4,30	5,00	6,00