

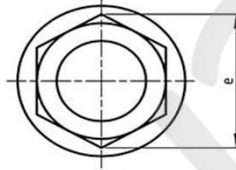

DIN7504K / UNI8117K - TRPAEZ ÇATI VİDALARI

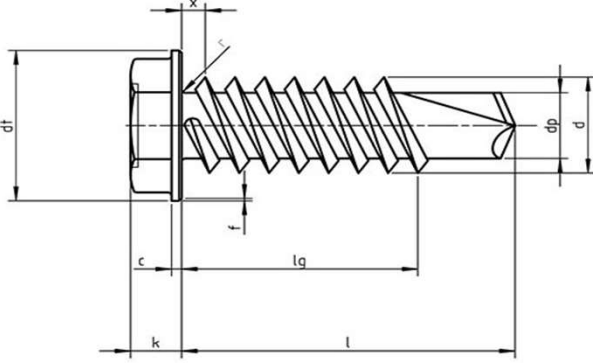

Ölçü d	3,5	3,9	4,2	4,8	5,5	6,3
c min.	0,60	0,60	0,90	0,90	1,00	1,00
dc max.	8,30	8,30	8,80	10,50	11,00	13,20
dc min.	7,60	7,60	8,20	9,80	10,00	12,20
f	0,40	0,40	0,40	0,50	0,50	0,50
e min.	5,96	5,96	7,59	8,71	8,71	10,95
k max.	3,45	3,45	4,25	4,45	5,45	6,45
k min.	3,20	3,20	4,00	4,15	5,15	6,15
k' min.	1,55	1,55	1,90	2,00	2,70	3,30
r max.	0,50	0,50	0,60	0,70	0,80	0,90
s	5,50	5,50	7,00	8,00	8,00	10,00
s min.	5,32	5,32	6,78	7,78	7,78	9,78
t min.	1,00	1,00	1,20	1,40	1,60	1,80
t max.	1,40	1,40	1,60	1,80	2,00	2,20
dp max.	2,80	3,10	3,60	4,10	4,80	5,80