

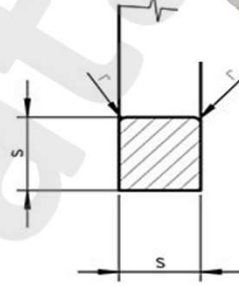

DIN 7980 YAYLI RONDELA KALIN TİP

DIN 7980 ;
CSN 21740;
PN 82008;
UNI 4464A;

* ST Çelik,
* A2 304
* A4 316

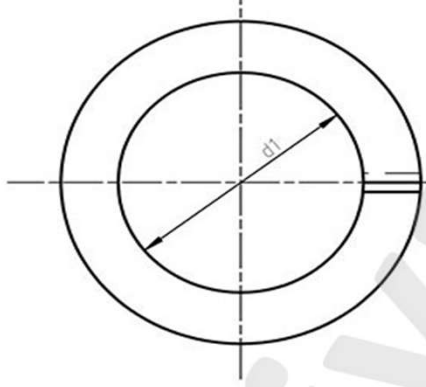
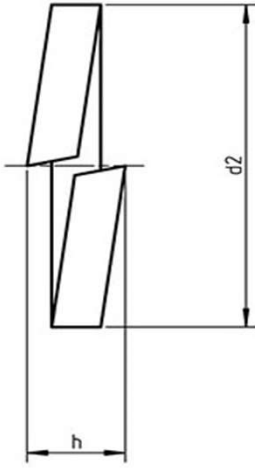

Anma Ölçüsü	d1	d1 min.	d1 max.	d2 max.	s	s tolerans	h min.	h max.	r
M3	3,00	3,10	3,40	5,60	1,00	±0,1	2,00	2,36	0,20
M3,5	3,50	3,60	3,90	6,10	1,00	±0,1	2,00	2,36	0,20
M4	4,00	4,10	4,40	7,00	1,20	±0,1	2,40	2,83	0,20
M5	5,00	5,10	5,40	8,80	1,60	±0,1	3,20	3,78	0,20
M6	6,00	6,10	6,50	9,90	1,60	±0,1	3,20	3,78	0,30
M8	8,00	8,10	8,50	12,70	2,00	±0,1	4,00	4,72	0,50
M10	10,00	10,20	10,70	16,00	2,50	±0,15	5,00	5,90	0,80
M12	12,00	12,20	12,70	18,00	2,50	±0,15	5,00	5,90	0,80
M14	14,00	14,20	14,70	21,10	3,00	±0,2	6,00	7,10	1,00
M16	16,00	16,20	17,00	24,40	3,50	±0,2	7,00	8,25	1,00
M18	18,00	18,20	19,00	26,40	3,50	±0,2	7,00	8,25	1,00
M20	20,00	20,20	21,20	30,60	4,50	±0,2	9,00	10,60	1,00
M22	22,00	22,50	23,50	32,90	4,50	±0,2	9,00	10,60	1,00
M24	24,00	24,50	25,50	35,90	5,00	±0,2	10,00	11,80	1,60
M27	27,00	27,50	28,50	38,90	5,00	±0,2	10,00	11,80	1,60
M30	30,00	30,50	31,70	44,10	6,00	±0,2	12,00	14,20	1,60
M33	33,00	33,50	34,70	47,10	6,00	±0,2	12,00	14,20	1,60
M36	36,00	36,50	37,70	52,20	7,00	±0,25	14,00	16,50	1,60
M42	42,00	42,50	43,70	60,20	8,00	±0,25	16,00	18,90	2,00
M48	48,00	49,00	50,50	67,00	8,00	±0,25	16,00	18,90	2,00