

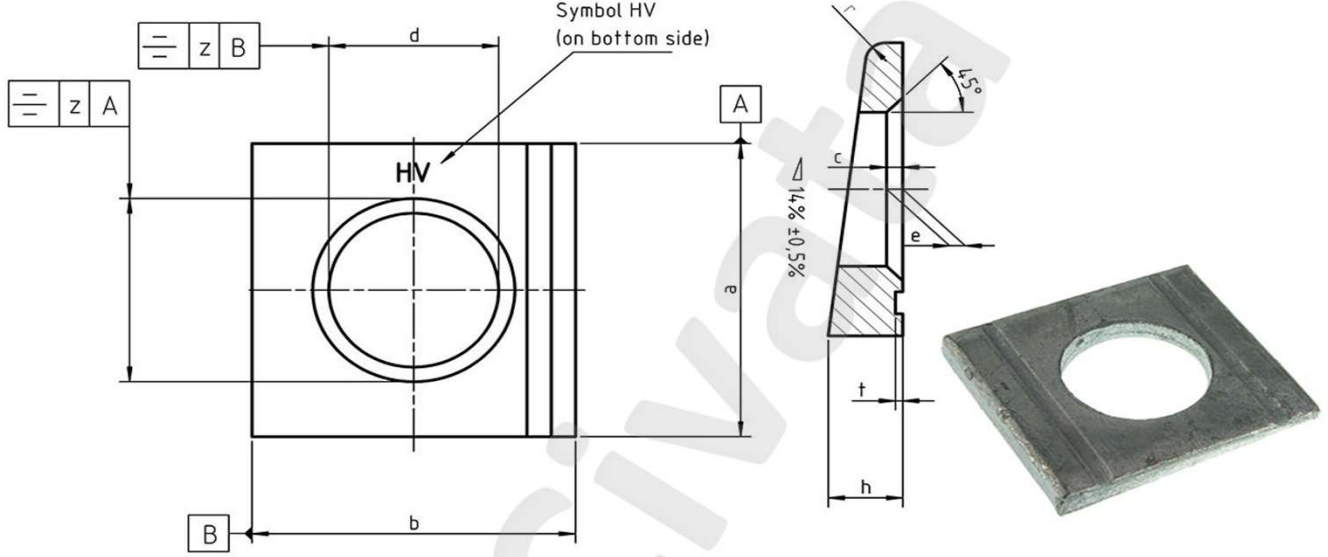

DIN 6917 UNI 5715 KARE KONİK PUL

- * ST Çelik,
- * A2 304
- * A4 316



Anma Ölçüsü	M12	M16	M20	M22	M24	M27	M30	M36
d	13,00	17,00	21,00	23,00	25,00	28,00	31,00	37,00
d min.	13,00	17,00	21,00	23,00	25,00	28,00	31,00	37,00
d max.	13,43	17,43	21,52	23,52	25,52	28,52	32,00	38,00
a	26,00	32,00	40,00	44,00	56,00	56,00	62,00	68,00
a min.	24,00	29,50	37,50	41,50	53,00	53,00	59,00	65,00
a max.	28,00	34,50	42,50	46,50	59,00	59,00	65,00	71,00
b	30,00	36,00	44,00	50,00	56,00	56,00	62,00	68,00
b min.	29,35	35,20	43,20	49,20	55,05	55,05	61,05	67,05
b max.	30,65	36,80	44,80	50,80	56,95	56,95	62,95	68,95
c	1,60	1,60	2,00	2,00	2,00	2,50	2,50	3,00
c max.	1,90	1,90	2,50	2,50	2,50	3,00	3,00	3,50
e	4,10	5,00	6,10	6,50	6,90	6,90	7,50	8,00
h	6,20	7,50	9,20	10,00	10,80	10,80	11,70	12,50
h min.	5,00	6,30	8,00	8,80	9,30	9,30	10,20	11,00
h max.	7,40	8,70	10,40	11,20	12,30	12,30	13,20	14,00
r	1,60	2,00	2,40	2,40	2,40	2,40	2,40	2,40
y	0,70	0,80	0,90	1,00	1,00	1,00	1,00	1,00
z	1,68	2,00	2,00	2,00	3,80	3,80	3,80	3,80