

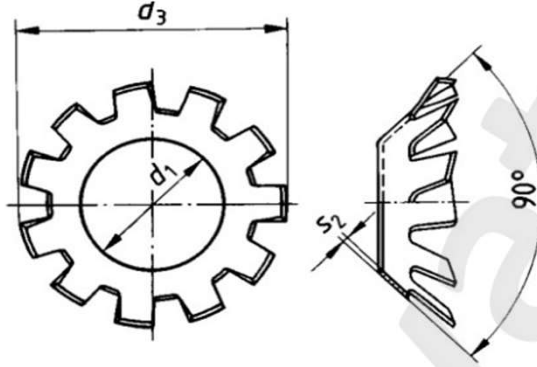

DIN 6797 V HAVŞA TIRTILLI PUL

DIN 6797 V;  
CSN 21744;  
UNI 8841;

\* ST Çelik,  
\* A2 304  
\* A4 316



| Anma Ölçüsü | d1    | d1 min. | d1 max | d3    | s2   | Diş   |
|-------------|-------|---------|--------|-------|------|-------|
| M2          | 2,20  | 2,20    | 2,34   | 4,20  | 0,20 | 6,00  |
| M2,5        | 2,70  | 2,70    | 2,84   | 5,10  | 0,20 | 6,00  |
| M3          | 3,20  | 3,20    | 3,38   | 6,00  | 0,20 | 6,00  |
| M3,5        | 3,70  | 3,70    | 3,88   | 7,00  | 0,25 | 6,00  |
| M4          | 4,30  | 4,30    | 4,48   | 8,00  | 0,25 | 8,00  |
| M5          | 5,30  | 5,30    | 5,48   | 9,80  | 0,30 | 8,00  |
| M6          | 6,40  | 6,40    | 6,62   | 11,80 | 0,40 | 10,00 |
| M8          | 8,40  | 8,40    | 8,62   | 15,30 | 0,40 | 10,00 |
| M10         | 10,50 | 10,50   | 10,77  | 19,00 | 0,50 | 10,00 |
| M12         | 13,00 | 13,00   | 13,27  | 23,00 | 0,50 | 10,00 |
| M14         | 15,00 | 15,00   | 15,27  | 26,20 | 0,60 | 12,00 |
| M16         | 17,00 | 17,00   | 17,27  | 30,20 | 0,60 | 12,00 |