

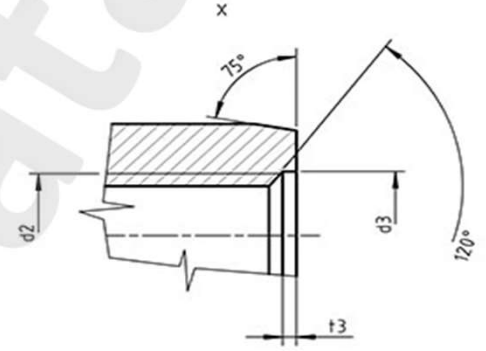

DIN 7979 DIN-EN-ISO 8735 ÇEKME Lİ DÜZ PİM

DIN 7979;
ISO 8735;
CSN 022151;
PN 85018;
UNI 6364;

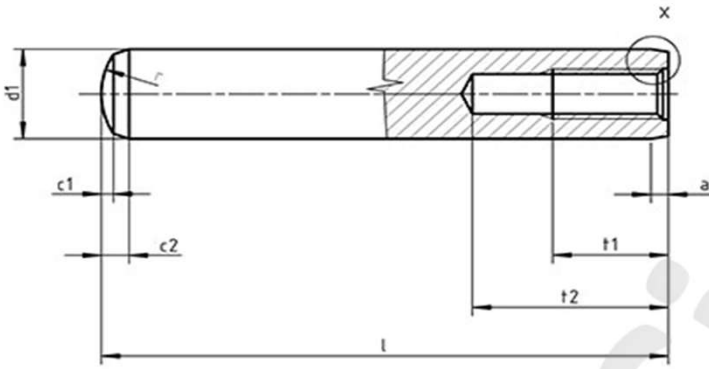
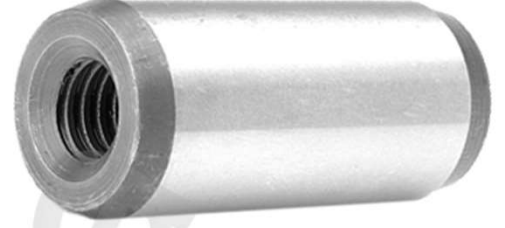

d m6	6	8	10	12	14	16	20
d2	M4	M5	M6	M6	M8	M8	M10
f1	2,10	2,60	3,00	3,80	4,00	4,70	6,00
f2	0,80	1,00	1,20	1,60	1,80	2,00	2,50
t	6,00	8,00	10,00	10,00	12,00	12,00	16,00