

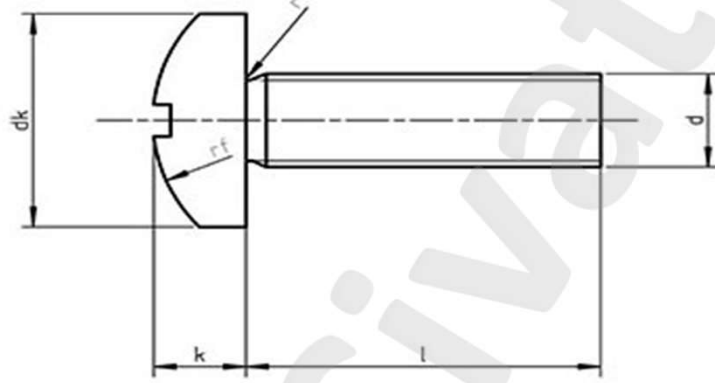

DIN 7985 ISO 7045 YILDIZ SİLİNDİR BAŞLI VİDA

DIN 7985;
ISO 7045;
CSN 21147;
PN 82202;
UNI 7687;

* 4,8
* 8.8.
* PA 6.6
* A2 304
* A4 316



Ölçü d	M1,6	M2	M2,5	M3	(M3,5)	M4	M5	M6	M8	M10
Diş Adm	0,35	0,40	0,45	0,50	0,60	0,70	0,80	1,00	1,25	1,50
a max.	0,70	0,80	0,90	1,00	1,20	1,40	1,60	2,00	2,50	3,00
da max.	2,10	2,60	3,10	3,60	4,10	4,70	5,70	6,80	9,20	11,20
dk max.	3,20	4,00	5,00	6,00	7,00	8,00	10,00	12,00	16,00	20,00
dk min.	2,90	3,70	4,70	5,70	6,64	7,64	9,64	11,57	15,57	19,48
k	1,30	1,60	2,00	2,40	2,70	3,10	3,80	4,60	6,00	7,50
k max.	1,42	1,72	2,12	2,52	2,82	3,25	3,95	4,75	6,15	7,68
k min.	1,18	1,48	1,88	2,28	2,58	2,95	3,65	4,45	5,85	7,32
r min.	0,10	0,10	0,10	0,10	0,20	0,20	0,20	0,25	0,40	0,40
rf	3,00	4,00	5,00	6,00	7,00	8,00	10,00	12,00	16,00	20,00
v	0,80	1,10	1,30	1,60	1,90	2,00	2,50	3,00	3,70	4,80
x max.	0,90	1,00	1,10	1,25	1,50	1,75	2,00	2,50	3,20	3,80
PH	0,00	1,00	1,00	1,00	2,00	2,00	2,00	3,00	4,00	4,00